

MODEL WS - 8

50% Movement

Application;

- ▶ Exterior walls (W/ Back seal or Vapor Barrier)
- ▶ Exterior ceilings
- ▶ Interior walls
- ▶ Interior Ceilings

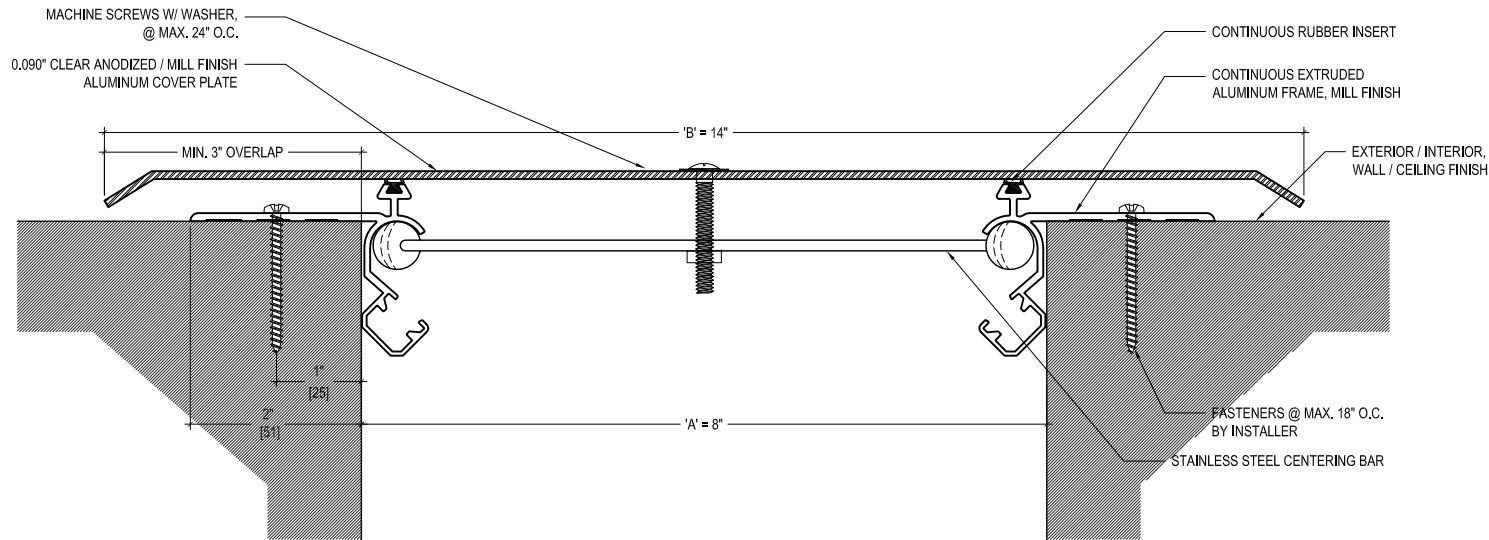

MODEL	A - VOID	MAX. OPENING	B - COVER
WS - 2	2" (50.80)	3" (76.20)	8" (203.20)
WS - 2-2	2" (50.80)	4" (101.60)	8" (203.20)
WS - 3	3" (76.20)	4 1/2" (114.30)	9" (228.60)
WS - 3-3	3" (76.20)	6" (152.40)	9" (228.60)
WS - 4	4" (101.60)	6" (152.40)	10" (254.00)
WS - 4-4	4" (101.60)	8" (203.20)	10" (254.00)
WS - 5	5" (127.00)	7 1/2" (190.50)	11" (279.40)
WS - 5-5	5" (127.00)	10" (254.00)	12" (302.80)
WS - 6	6" (152.40)	9" (228.60)	12" (302.80)
WS - 6-6	6" (152.40)	12" (302.80)	14" (355.60)
WS - 7	7" (177.80)	10 1/2" (266.70)	13" (330.20)
WS - 7-7	7" (177.80)	14" (355.60)	16" (406.40)
* WS - 8	8" (203.20)	12" (302.80)	14" (355.60)
WS - 8-8	8" (203.20)	16" (406.40)	18" (457.20)
WS - 9	9" (228.60)	13 1/2" (342.90)	16" (406.40)
WS - 9-9	9" (228.60)	18" (457.20)	20" (508.00)
WS - 10	10" (254.00)	15" (381.00)	17" (431.80)

'B' COVER PLATE = 'A' VOID X (MOVEMENT %) + 2"
 MINIMUM 'B' COVER PLATE = 'A' VOID + (2 X 3")



M.H. POWELL & CO., INC.

ARCHITECTURAL SEISMIC EXPANSION JOINT SYSTEMS

2313 YATES AVENUE | PHONE : (323) 887-0037
 COMMERCE, CA 90040 | FAX : (323) 887-0877
 WEB : www.mhpowell.net

MODEL WS - 8

W/ BACK SEAL - OPTIONAL

PROJECT : _____ PROJECT # : _____
 LOCATION : _____ DATE : _____
 ARCHITECT : _____
 CUSTOMER : _____

PAGE #