

MODEL WE - 8
50% Movement

Application;

- ▶ Exterior walls (W/ Back seal or Vapor Barrier)
- ▶ Exterior ceilings
- ▶ Interior walls
- ▶ Interior Ceilings

WE-2	2" (50.80)	3" (76.20)	10" (254.00)
WE-2-2	2" (50.80)	4" (101.60)	10" (254.00)
WE-3	3" (76.20)	4 1/2" (114.30)	11" (279.40)
WE-3-3	3" (76.20)	6" (152.40)	11" (279.40)
WE-4	4" (101.60)	6" (152.40)	12" (304.80)
WE-4-4	4" (101.60)	8" (203.20)	12" (304.80)
WE-5	5" (127.00)	7 1/2" (190.50)	13" (330.20)
WE-5-5	5" (127.00)	10" (254.00)	13" (330.20)
WE-6	6" (152.40)	9" (228.60)	14" (355.60)
WE-6-6	6" (152.40)	12" (304.80)	14" (355.60)
WE-7	7" (178.80)	10 1/2" (266.70)	15" (381.00)
WE-7-7	7" (178.80)	14" (355.60)	16" (406.40)
* WE-8	8" (203.20)	12" (304.80)	16" (406.40)
WE-8-8	8" (203.20)	16" (406.40)	18" (457.20)
WE-9	9" (228.60)	13 1/2" (342.90)	17" (431.80)
WE-9-9	9" (228.60)	18" (457.20)	20" (508.00)
WE-10	10" (254.00)	15" (381.00)	18" (457.20)

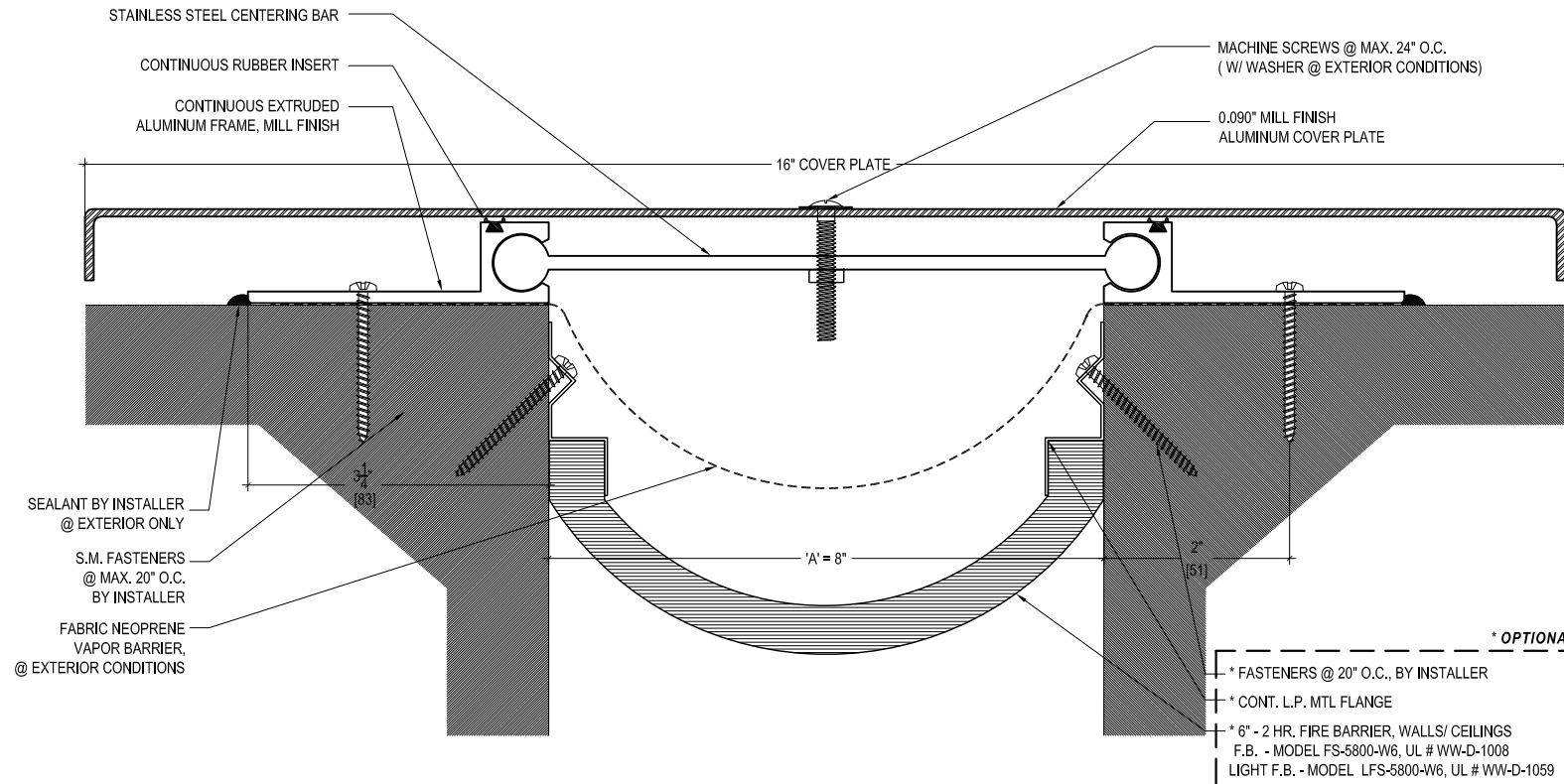

M.H. POWELL & CO., INC.
ARCHITECTURAL SEISMIC EXPANSION JOINT SYSTEMS

2313 YATES AVENUE | PHONE : (323) 887-0037
 COMMERCE, CA 90040 | FAX : (323) 887-0877
 | WEB : www.mhpowell.net

MODEL WE - 8
WALLS - EXTERIOR / INTERIOR

PROJECT : _____ PROJECT # : _____
 LOCATION : _____ DATE : _____
 ARCHITECT : _____
 CUSTOMER : _____