

**MODEL WE - 8-8**  
100% Movement

**Application;**

- ▶ Exterior walls (W/ Back seal or Vapor Barrier)
- ▶ Exterior ceilings
- ▶ Interior walls
- ▶ Interior Ceilings

WE-2	2" (50.80)	3" (76.20)	10" (254.00)
WE- 2-2	2" (50.80)	4" (101.60)	10" (254.00)
WE-3	3" (76.20)	4 1/2" (114.30)	11" (279.40)
WE- 3-3	3" (76.20)	6" (152.40)	11" (279.40)
WE- 4	4" (101.60)	6" (152.40)	12" (304.80)
WE- 4-4	4" (101.60)	8" (203.20)	12" (304.80)
WE- 5	5" (127.00)	7 1/2" (190.50)	13" (330.20)
WE- 5-5	5" (127.00)	10" (254.00)	13" (330.20)
WE- 6	6" (152.40)	9" (228.60)	14" (355.60)
WE- 6-6	6" (152.40)	12" (304.80)	14" (355.60)
WE- 7	7" (178.80)	10 1/2" (266.70)	15" (381.00)
WE- 7-7	7" (178.80)	14" (355.60)	16" (406.40)
WE - 8	8" (203.20)	12" (304.80)	16" (406.40)
* WE- 8-8	8" (203.20)	16" (406.40)	18" (457.20)
WE- 9	9" (228.60)	13 1/2" (342.90)	17" (431.80)
WE- 9-9	9" (228.60)	18" (457.20)	20" (508.00)
WE- 10	10" (254.00)	15" (381.00)	18" (457.20)

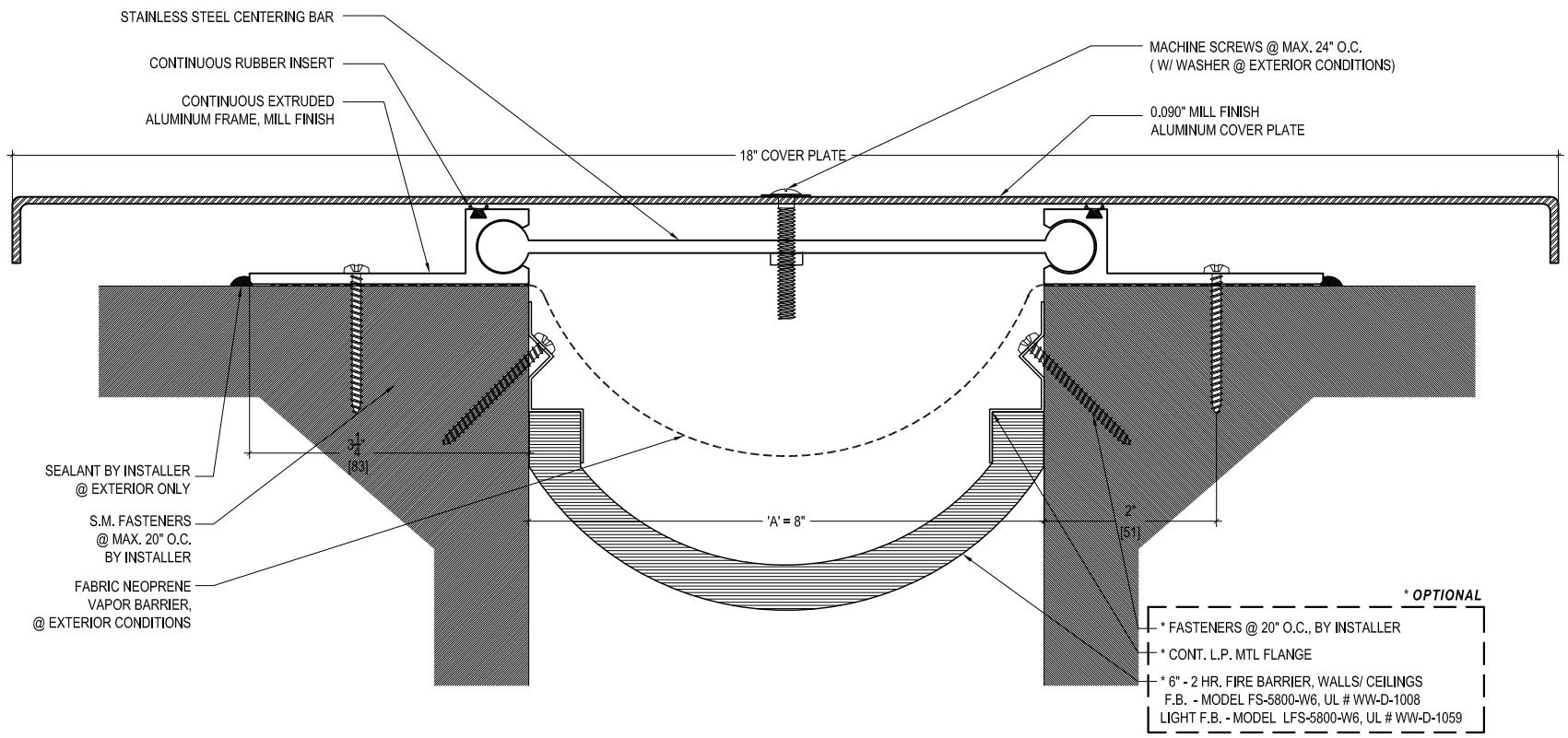

- \* OPTIONAL**
- \* FASTENERS @ 20" O.C., BY INSTALLER
  - \* CONT. L.P. MTL FLANGE
  - \* 6" - 2 HR. FIRE BARRIER, WALLS/ CEILINGS  
F.B. - MODEL FS-5800-W6, UL # WW-D-1008
  - LIGHT F.B. - MODEL LFS-5800-W6, UL # WW-D-1059



**M.H. POWELL & CO., INC.**  
ARCHITECTURAL SEISMIC EXPANSION JOINT SYSTEMS

2313 YATES AVENUE | PHONE : (323) 887-0037  
 COMMERCE, CA 90040 | FAX : (323) 887-0877  
 | WEB : www.mhpowell.net

**MODEL WE - 8-8**  
WALLS - EXTERIOR / INTERIOR

PROJECT : \_\_\_\_\_ PROJECT # : \_\_\_\_\_

LOCATION : \_\_\_\_\_ DATE : \_\_\_\_\_

ARCHITECT : \_\_\_\_\_

CUSTOMER : \_\_\_\_\_